

## Drilling template

- 10mm (0.39") diameter hole for wire entry
- 3 x 3.6mm (0.14") diameter holes for mounting screws

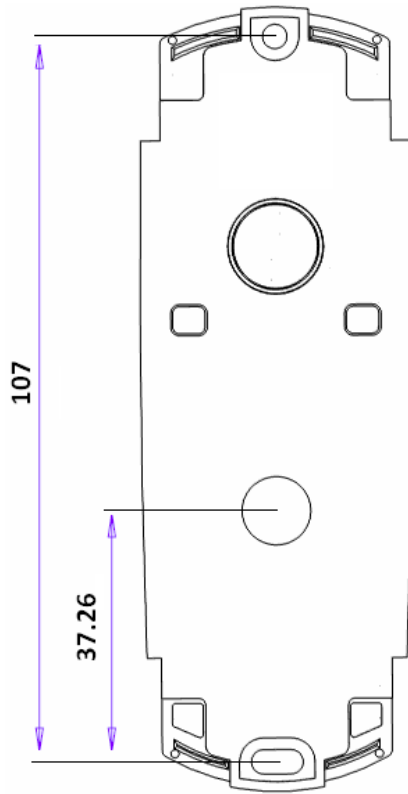

## Wiring diagram

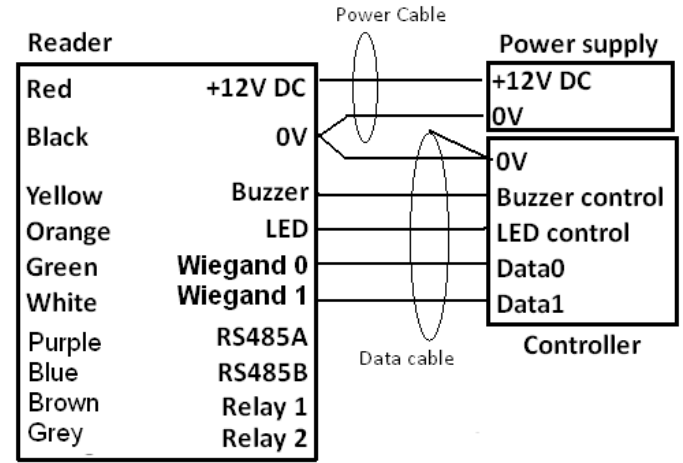

### Note:

- A shielded cable is recommended to be used. The shield is connected to controller 0V reference
- Maximum wiegand data cable length: 150 meters (500 feet)
- Buzzer and LED are activated when buzzer and LED line go below 2.5V.
- RS485 lines and Relay lines are only for optional use
- Terminate or insulate all un-used wires

### Regulatory Information

**C-Tick:** This device is C-Tick complied.

**CE:** The device has passed all relevant tests and obtained CE approval.

**FCC:** This device complies with Part 15 of the FCC Rules. Operation is subject to the following two conditions: 1) this device may not cause harmful interference and 2) this device must accept any interference received, including interference that may cause undesired operation of the device.

**Warning:** This equipment has been tested and found to comply with the limits for a Class B digital device, pursuant to part 15 of the FCC rules. These limits are designed to provide reasonable protection against harmful interference in a residential installation. This equipment generates uses and can radiate radio frequency energy and, if not installed and used in accordance with the instructions, may cause harmful interference to radio communications. However, there is no guarantee that interference will not occur in a particular installation. If this equipment does cause harmful interference to radio or television reception, which can be determined by turning the equipment off and on, the user is encouraged to try to correct the interference by one or more of the following measures:

- Reorient or relocate the receiving antenna.
- Increase the separation between the equipment and receiver.
- Connect the equipment into an outlet on a circuit different from that to which the receiver is connected.
- Consult the dealer or an experienced radio/TV technician for help.

Any changes or modifications not expressly approved by BQT Solutions could void the user's authority to operate this equipment.

## Specifications

<b>Output protocols</b>	Wiegand or RS485	
<b>Power requirement</b>	6 – 18V DC (Nominal operating voltage 12V DC)	
<b>Model</b>	BT950-ST	BT950-DT
<b>Current Consumption</b>	39mA (Avg) 84mA (Peak)	66mA (Avg) 111mA (Peak)
<b>Frequency</b>	13.56MHz	125KHz/13.56MHz
<b>Relay Rating</b>	80mA	
<b>Read range</b>	20-40mm (0.8"-1.6") at 12V DC depends on the type of card used	
<b>Operating temperature</b>	-25°C to +65°C (-13°F to 149°F)	
<b>Relative humidity</b>	90% max, operating non-condensing	
<b>Reader dimensions</b>	119mm(L) x 43mm(W) x 21mm (D) (4.69"x1.69"x0.83")	
<b>Status LED</b>	Green & Red	
<b>Audible tone</b>	Internal and external buzzer control, Configurable using "Configuration Card"	
<b>Colour finish</b>	Charcoal	
<b>IP rating</b>	IP65	

Information obtained in this document is subject to change without notice.

For further technical information, visit our website at [www.bqtsolutions.com](http://www.bqtsolutions.com) or email [techsupport@bqtsolutions.com](mailto:techsupport@bqtsolutions.com).

Alternatively contact us at one of our global locations

**AUSTRALIA & PACIFIC**  
BQT Solutions (Australia) Pty Limited  
Unit 29, 1 Talavera Road  
North Ryde, NSW 2113, Australia  
Phone: +61 (0)2 8817 2800  
Fax: +61 (0)2 8817 2811  
Email: [sales@bqtsolutions.com](mailto:sales@bqtsolutions.com)

**EUROPE AND MIDDLE EAST**  
BQT Solutions (UK) Limited  
Regus, Castle Court, 41 London Road  
Reigate, RH2 9RJ  
United Kingdom  
Phone: +44 (0)17 3773 5071  
Fax: +44 (0)17 3773 5072  
Email: [salesuk@bqtsolutions.com](mailto:salesuk@bqtsolutions.com)

**GREATER ASIA**  
BQT Solutions Singapore Office  
Mediapolis  
71 Ayer Rajah Crescent #03-03  
Singapore 139951  
Phone: +65 6220 7970  
Fax: +65 6220 7656  
Email: [salesasia@bqtsolutions.com](mailto:salesasia@bqtsolutions.com)



# BT950

## INSTALLATION GUIDE

Version 1.2



smartersecuritytoday

## Disassemble

1. Use fingers to squeeze the reader cover at the location where the arrows are pointing to
2. Pull the cover from the top of reader



**Note:** DO NOT use a screw driver or other implement to remove cover. Incorrect removal of cover may damage the LED and void the warranty.

## Mounting

1. If necessary, use the drilling template provided to drill holes.

2. The mounting screw size is #3 gauge.

**Note:** Be careful of cables when drilling

For installation on standard electrical gang box, a universal mounting adaptor plate (BQT Part number: BP-BM) can be used. Please contact BQT for further information.

## Wire connection

### Note:

Power to the unit is provided from the listed control unit or from a separately UL listed 12V DC power-limited, access control power source. DO NOT supply power during installation.

Wiring methods shall be in accordance with the Electrical wiring regulation in your country / region.

Check your circuit diagram for the colour coding of the circuit wiring. The reader can be damaged beyond repair if the wiring is connected incorrectly. This will void the warranty.

1. Connect the 0V wire to the power 0V line;  
**Note:** The 0V line of all power supplies must be connected to a common 0V reference point.
2. Connect the Wiegand data wires;
3. Connect the Buzzer and LED wires;
4. Connect 12V DC wire;
5. Place reader on the wall (Make sure the wires are not crushed. This will void the warranty of damage occurs)
6. Insert and hand tighten the screws;
7. Check that the reader is level before tightening the screws;  
**Note:** Excessive tightening of screws may deform the casing, resulting in a damaged unit. This will void the warranty.
8. Turn on the 12V DC power to power up reader.
9. Allow 5 – 10 seconds for reader to finish initialization (depends on the application). Make sure reader is functioning correctly according to the application specification.

## Cover

After checking reader function, attach front cover back to the reader

1. Align the bottom of front cover with the bottom of reader;  
**Note:** Make sure LED is aligned to the LED hole on the cover;
2. Push the cover onto reader and a click sound can be heard.

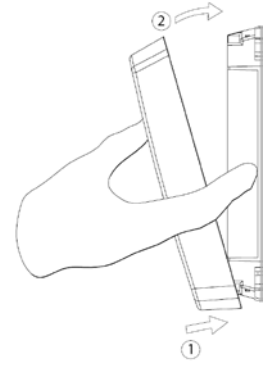

## External Use

- Make sure the wire bundle to the reader has an IP rating of at least IP65

## Handling

- Handle the reader with care. DO NOT damage or drop unit before installation. This will void the warranty.
- If the case is damaged, the reader may not be to the specified IP rating. Replace the reader if the case is damaged.

## Maintenance

- Once installed the reader requires no maintenance.

## Troubleshooting

Problem	Troubleshooting steps
Power on reader – reader does not start up	<ol style="list-style-type: none"> <li>1. Check connections</li> <li>2. Check the voltage at the reader</li> <li>3. Check the current capability of the power supply</li> </ol>
Power on reader – reader keeps beeping	<ol style="list-style-type: none"> <li>1. Check buzzer line</li> <li>2. Check the voltage at the reader</li> <li>3. Check the current capability of the power supply</li> </ol>
Power on reader – LED stays green	<ol style="list-style-type: none"> <li>1. Check LED line</li> </ol>
Present a card to reader – a beep is heard but reader does not output any data	<ol style="list-style-type: none"> <li>1. Check whether the card has data encoded</li> <li>2. Check the wiegand connection to controller</li> <li>3. Check the voltage level on wiegand data lines</li> </ol>
Present a card to reader – no response from reader	<ol style="list-style-type: none"> <li>1. Try a known working card</li> <li>2. Check if the reader requires to be configured with a configuration card</li> </ol>

If the problem still persists, please contact your distributor for technical support.

## Warranty

Unless specified otherwise, the Company warrants to the Customer that 'BQT Solutions Branded Products' (excluding third party products and software) are covered by a return to base warranty on defects in materials and workmanship affecting normal use for a period of the Warranty offered under the Standard Terms and Conditions of Sale from BQT invoice date ('Standard Warranty')

This standard warranty does not cover damage, fault, failure or malfunction due to external causes including; accident, misuse, problems with electrical power, servicing not authorised by the Company, usage and/or storage and/or installation not in accordance with Product instructions, failure to perform required preventative maintenance, normal wear and tear, act of God, fire, flood, war, any violent or similar occurrence; any attempt by any person other than Company personnel or any person authorised by the Company to repair or support the Products and problems caused by use of parts and components not supplied by the Company. The standard warranty does not cover any items that are in one or more of the following categories: software; external devices; accessories or parts added to the product after the product has been shipped from BQT Solutions.

During the warranty, period beginning on the invoice date, the Company will repair or replace faulty products (at its absolute discretion) returned to its' factory. The Customer must prepay shipping and transportation costs and insure the shipment or accept the risk of loss or damage during such transportation.

The Customer shall be solely responsible for determining suitability for use and the Company will, in no event, be liable in this respect. This standard warranty is given in place of all warranties, conditions, terms, undertakings and obligations implied by statute, common law, trade usage, and course of dealing or otherwise including warranties or conditions of merchantability, fitness for purpose, satisfactory quality and / or compliance with description, all of which are hereby excluded to the fullest extent permitted by law.